



- ▶ Heavy-duty steel construction making it impact resistant
- ▶ Safety yellow powder coat finish
- ▶ Protects bottom panel of the overhead door from damage when gate is down
- ▶ Protects overhead door track when gate is up
- ▶ Available in 36" and 48" widths
- ▶ Manual operation is standard but can be interlocked to work with other loading dock equipment

DOOR SHIELD™

PROTECTIVE SYSTEMS



The left gate is shown with optional extended cart shield. The right gate is shown as standard.

The Door SHIELD™ is designed to protect the bottom panel of the overhead door from the daily dings and collisions caused by pallets and rolling carts. The Door SHIELD lowers in front of the door protecting the bottom panel by engaging with the floor or dock leveler preventing items from being pushed into the door.

The Door SHIELD utilizes an under door lip which prevents the door from being closed before the Door SHIELD is in position. The door SHIELD is available in both the standard height or with the optional extended cart shield. The Door SHIELD can be used with either mechanical or powered doors and can be interlocked electronically to the overhead door or dock leveler with the optional interconnect limit switch.

Designed by Allied Solutions to be a marvel of simplicity and efficiency, the Door SHIELD will provide many years of trouble free performance and offer you the protection you need for the overhead door.



W194 N11481 McCormick Drive • Germantown, WI 53022
Phone: 1.800.643.5424 • Email: sales@allieddocksolutions.com

www.allieddocksolutions.com

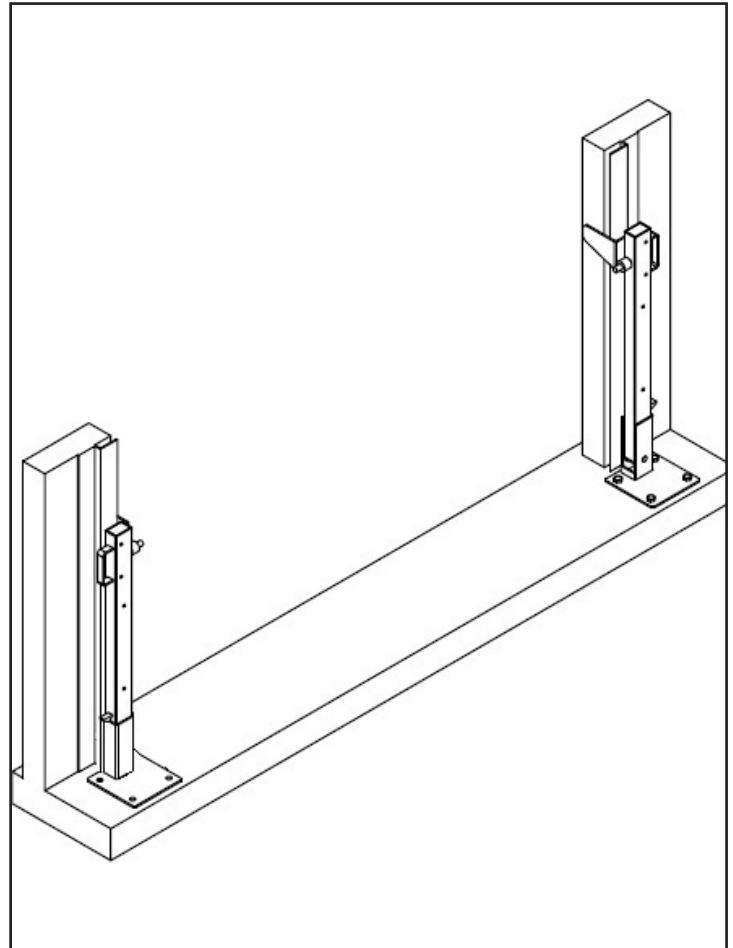

In the open position the left and right gate lock securely into the carriage on either side.

DISTRIBUTED BY: